

## SCHEMELE UNUI MICROCALCULATOR PERSONAL COMPATIBIL CU ZX SPECTRUM

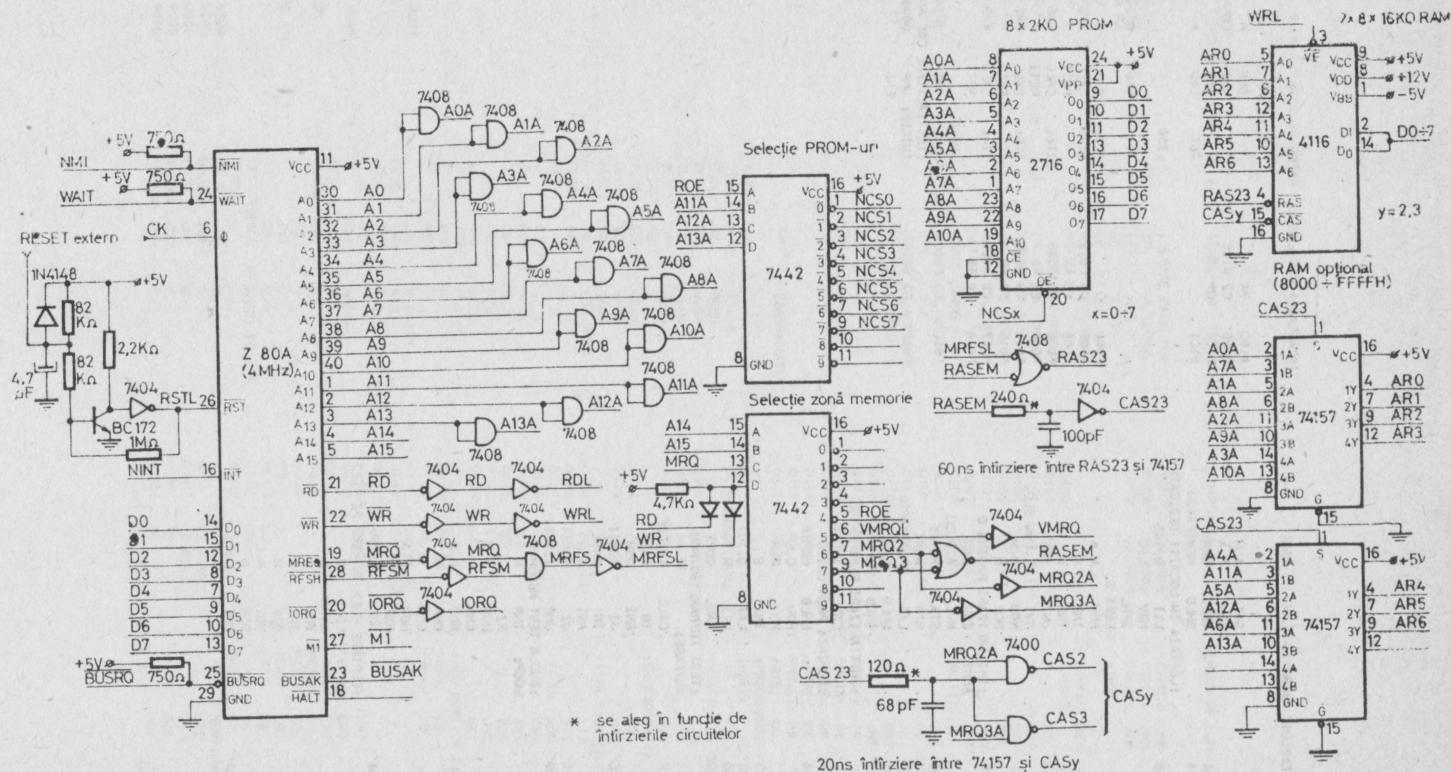

Microcalculator personal compatibil cu ZX Spectrum. Z80, RAM-optional, selecții PROM, RAM, inițializare

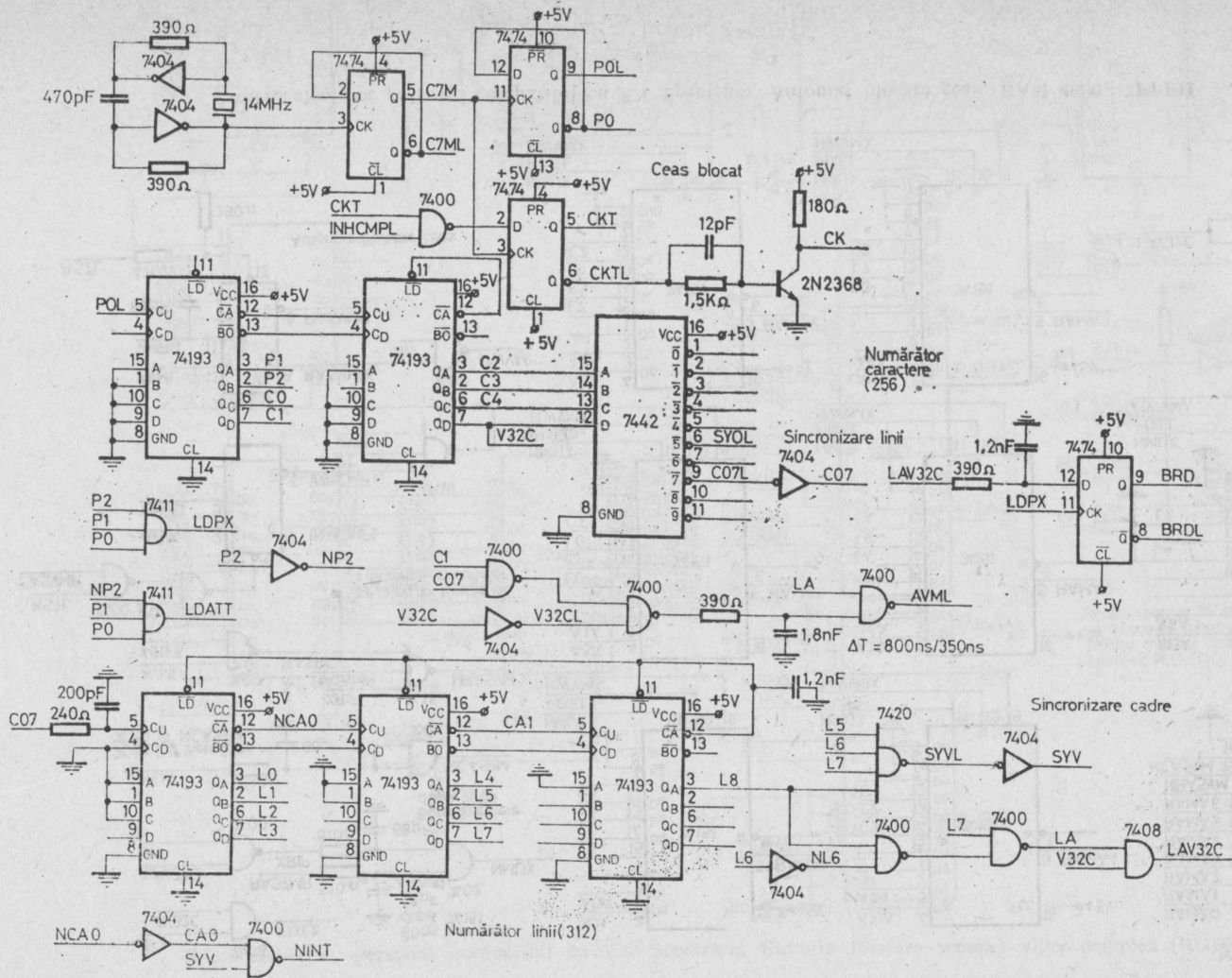

Microcalculator personal compatibilii cu ZX Spectrum. Ceas, numărătoare de caractere și linii

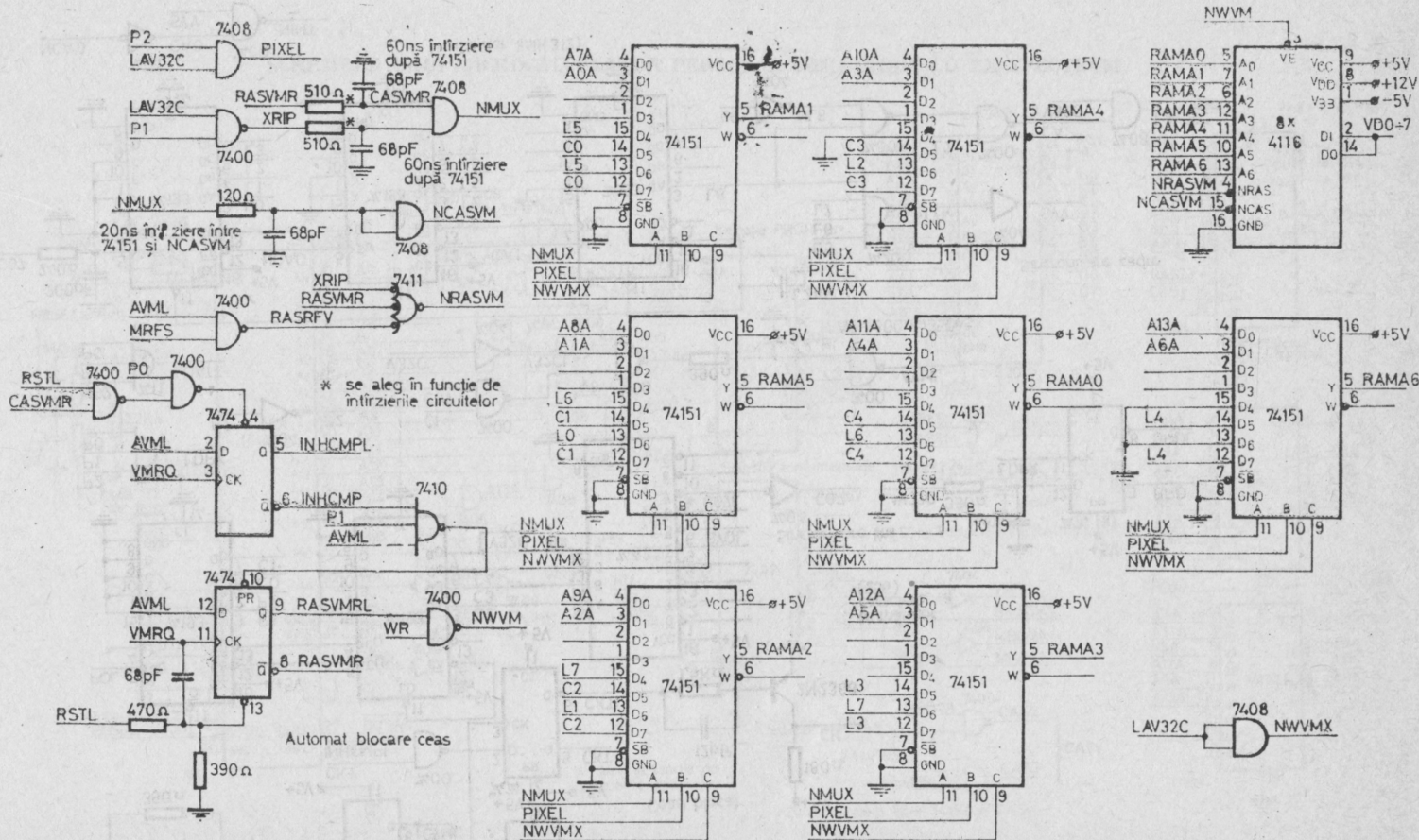

Microcalculator personal compatibil cu ZX Spectrum. Automat blocare ceas, RAM 4000 ÷ 7FFFH

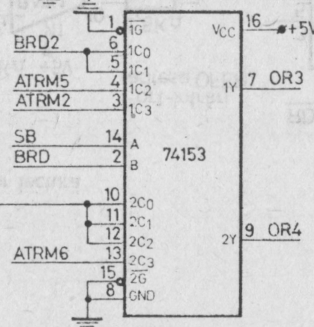
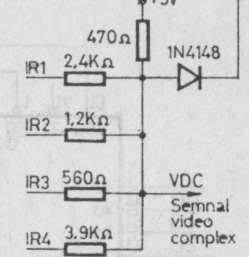
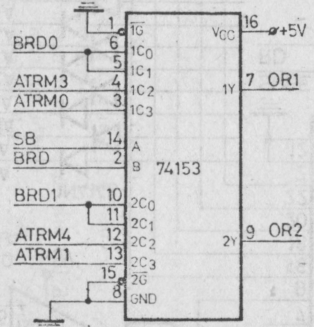
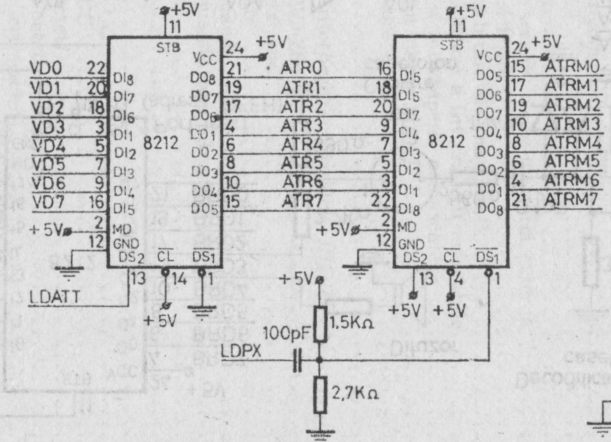
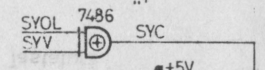
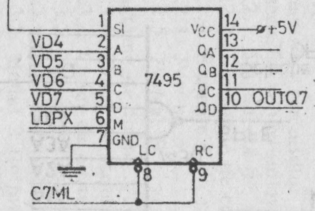
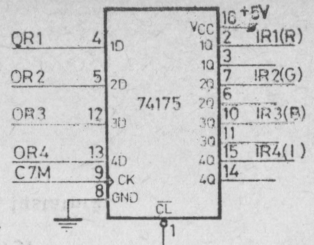
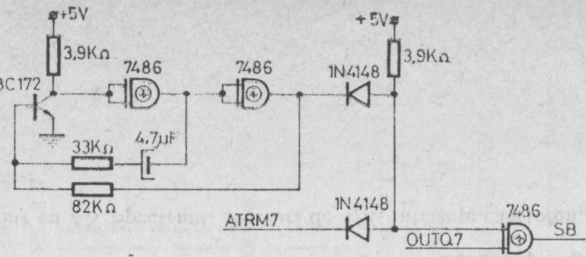
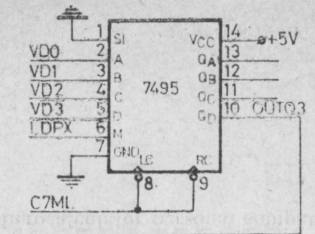

Pentru monitor TV alb-negru se foloseste schema data; pentru monitor color se folosesc R, G, B, I.

Microcalculator personal compatibil cu ZX Spectrum. Circuite formare semnal video complex (RGB)

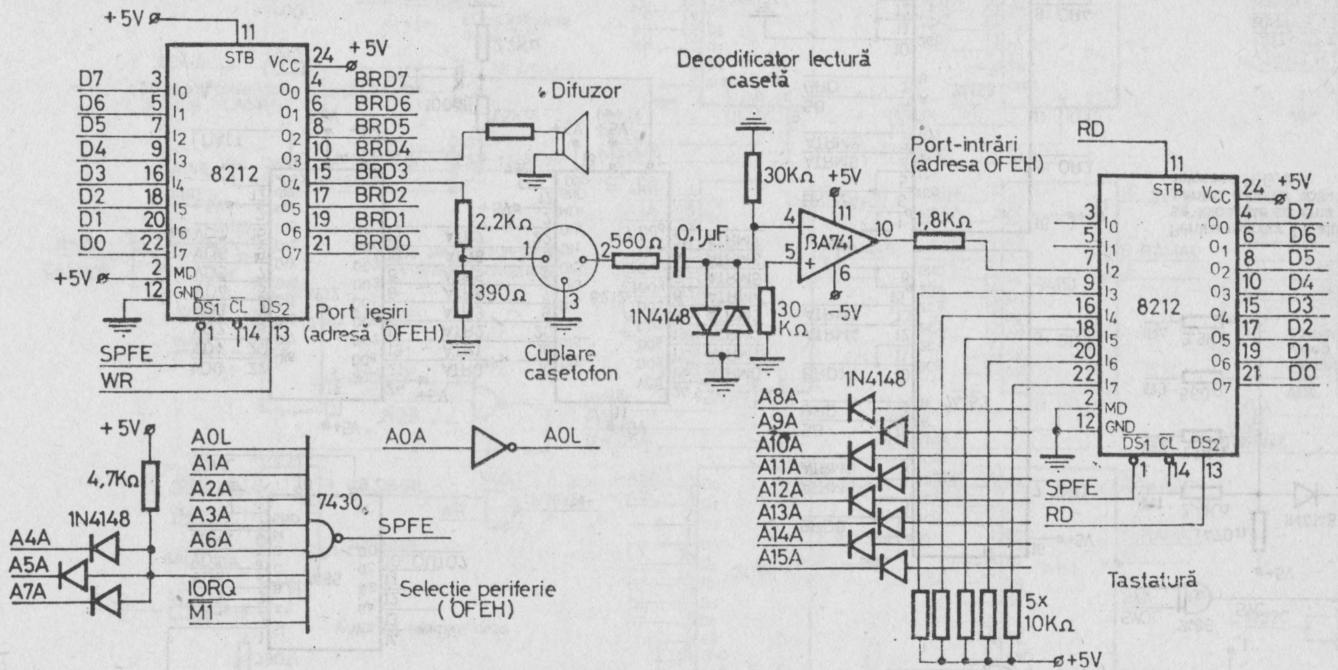

Microcalculator personal compatibil cu ZX Spectrum. Port-uri de I/E, interfețe casetofon, tastatură